

LT-701-12A 1-10V LED Dimming Driver



LTECH developed a new 0/1-10V to PWM dimming driver which has solved the compatible problem of the fluorescent dimming system and the LED illumination. LED lamps can be controlled by many traditional intelligent dimming systems such as Lutron, Dynalite, Tridonic, Schneider, Clipsal, Osram, Philips, ABB, etc.

LT-701-12A CV dimming driver is compatible with the active/passive 0-10V, 1-10V, 10V PWM and the PUSH BUTTON insert dimming, It can load max. 12A current, 12V can load max 144W, 24V can load max. 288W.

0-100% PWM dimming, output with the dimming curve that is more palatable to human vision, provide the user with more comfortable and natural lighting experience.

* By working with our CC 0/1-10V dimming driver, the basic issue that related LED projects and needs 0/1-10V dimming can be solved.

1. Product Parameter:

LT-701-12A 1-10V LED Dimming Driver

- Input Signal: 0-10V, 1-10V, 10VPWM or Push Button
- Input Voltage: 12~24V DC
- Output Current: 12A×1CH Max. 12A
- Max. Output Power: 144W/288W(12V/24V)
- Dimming Range: 0~100%
- Working Temperature: -30℃~55℃
- Product Size: L175×W44×H30(mm)
- Package Size: L178×W48×H33(mm)
- Weight(G.W.): 125g

2. Product Size:

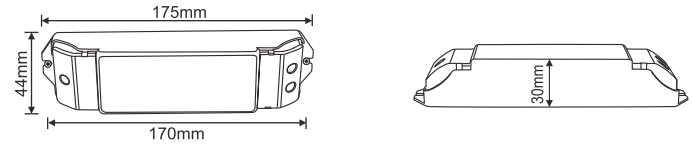

3. Conjunction Diagram:

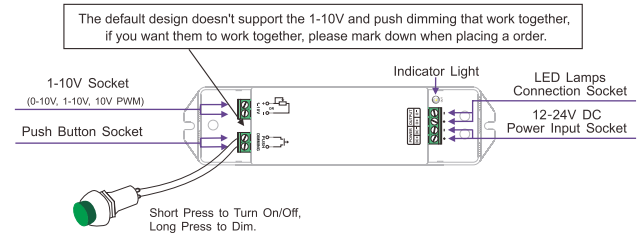

3.1 Connection Diagram for Single Unit :

Example 1: Connected with 12V strip, Max 144W(12V).

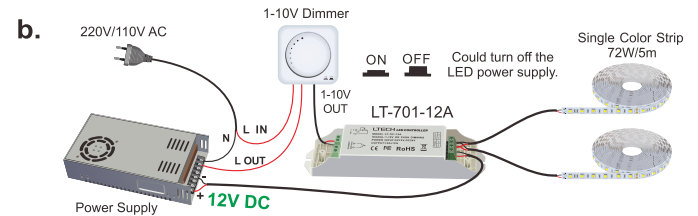
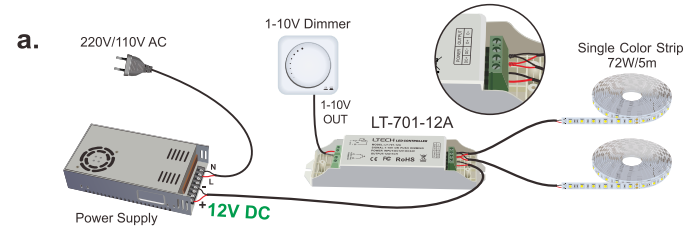

Example 2: Connected with 24V strip, Max 288W(24V).

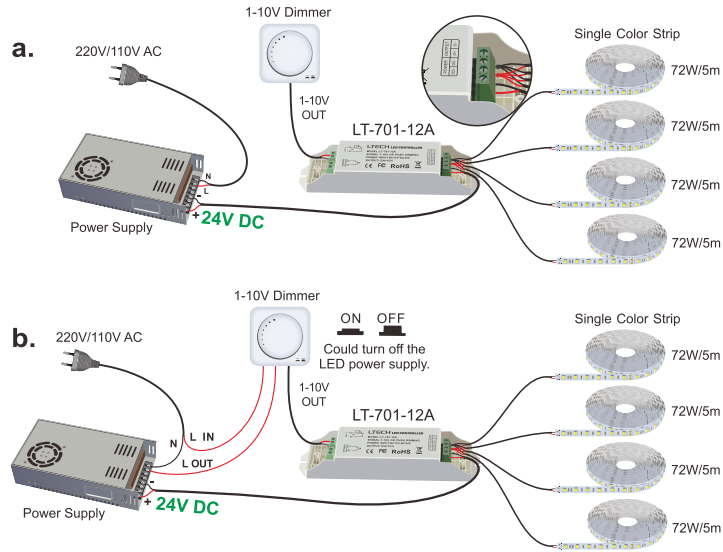

3.2 System Connection Diagram:

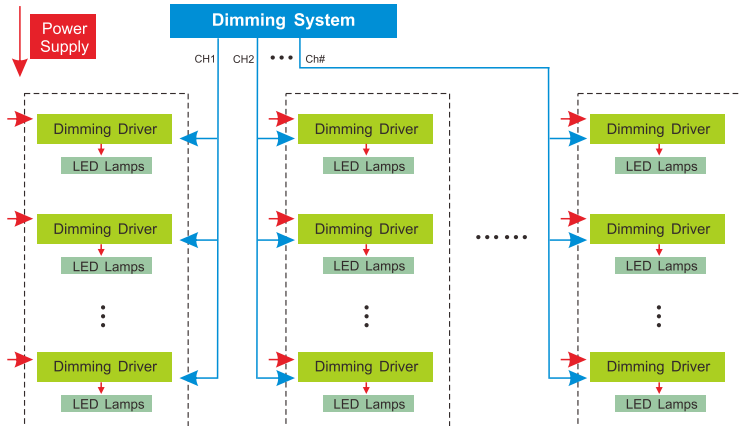

4. Attention:

- 4.1 The product shall be installed and serviced by the qualified person.
- 4.2 This product is non-waterproof. Please avoid the sun and rain. When installed outdoors, please ensure it is mounted in a water proof enclosure.
- 4.3 Good heat dissipation will prolong the working life of the controller. Please ensure good ventilation.
- 4.4 Please check if the output voltage of the LED power supply used comply with the working voltage of the product.
- 4.5 Please ensure that adequate sized cable is used from the controller to the LED lights to carry the current. Please also ensure that the cable is secured tightly in the connector.
- 4.6 Ensure all wire connections and polarities are correct before applying power to avoid any damages to the LED lights.
- 4.7 If a fault occurs, please return the product to your supplier. Do not attempt to fix this product by yourself.

5. Warranty Agreement:

- 5.1 We provide lifelong technical assistance with this product:
 - A 5-year warranty is given from the date of purchase. The warranty is for free repair or replacement if cover manufacturing faults only.
 - For faults beyond the 5-year warranty, we reserve the right to charge for time and parts.
 - 5.2 Warranty exclusions below:
 - Any man-made damages caused from improper operation, or connecting to excess voltage and overloading.
 - The product appears to have excessive physical damage.
 - Damage due to natural disasters and force majeure.
 - Warranty label, fragile label and unique barcode label have been damaged.
 - The product has been replaced by a brand new product.
 - 5.3 Repair or replacement as provided under this warranty is the exclusive remedy to the customer. LTECH shall not be liable for any incidental or consequential damages for breach of any stipulation in this warranty.
 - 5.4 Any amendment or adjustment to this warranty must be approved in writing by LTECH only.
- ★This manual only applies to this model. LTECH reserves the right to make changes without prior notice.