

LT-820-5A 16bit DMX CV Decoder

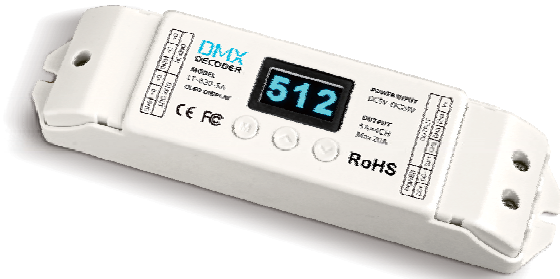

LT-820-5A is the world's first OLED display DMX decoder, designed for LED dimming, produce great lighting effects, can be worked with any brand of DMX dimmer, outstanding performance with following features:

- OLED real-time display.
- 16bit/8bit input.
- 3 dimming curve optional.
- Frame rate is as high as 850 FPS.
- Built-in protection circuit of resistance to lightning stroke and ESD static electricity.

1. Product Parameter:

LT-820-5A PWM CV Decoder

- | | |
|---|---|
| <ul style="list-style-type: none"> • Input Signal : DMX512 • Input Voltage : DC5V-DC24V • Max Load Current : 5A x 4CH Max 20A • Max Output Power : 100W/240W/480W(5V/12V/24V) • Dimming Range : 0~100% | <ul style="list-style-type: none"> • Working Temperature : -30°C~55°C • Dimensions : L175×W44×H30mm • Package Size : L178×W48×H33mm • Weight (G.W.): 120g |
|---|---|

2. Product Size:

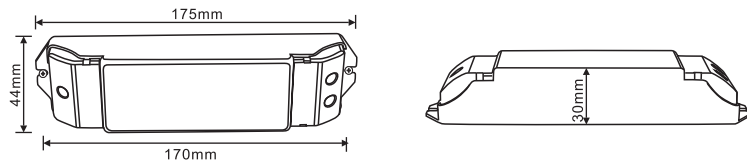

3. Parts Figure:

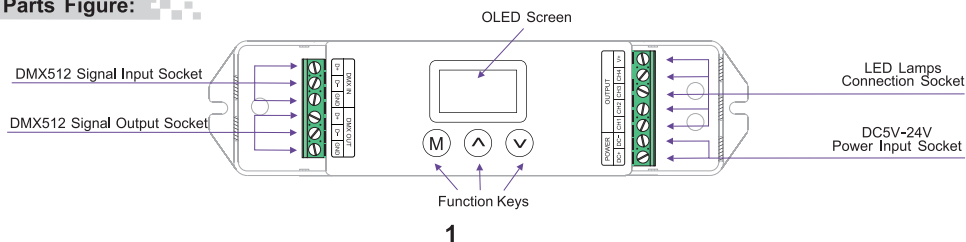

4. OLED Screen Interface Diagram:

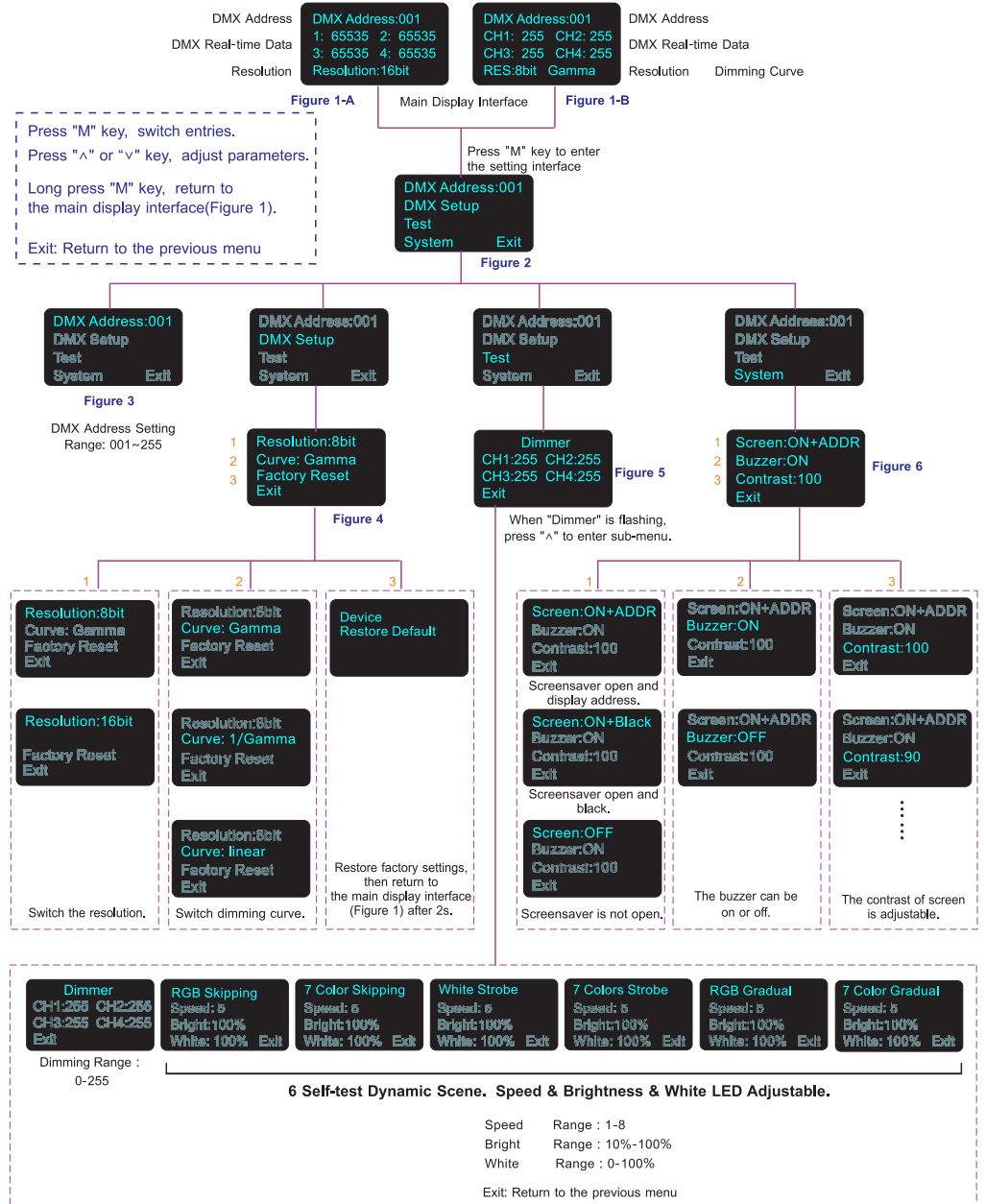

LT-820-5A will run the test scenes only when you enter "self-test" interface. Screensaver enable time: undo for 2 min in the main display interface (Figure 1).
[Restore the default parameters] : In the main display interface(Figure 1) , Long press "M"/"^"/"v" 3 keys simultaneously, LT-820-5A will restore the default parameters, and the screen display"Device restore default" for 2s, then it will return to the main display interface (Figure 1)

5. Conjunction Diagram:

1) Wiring Diagram for Multiple Unit :

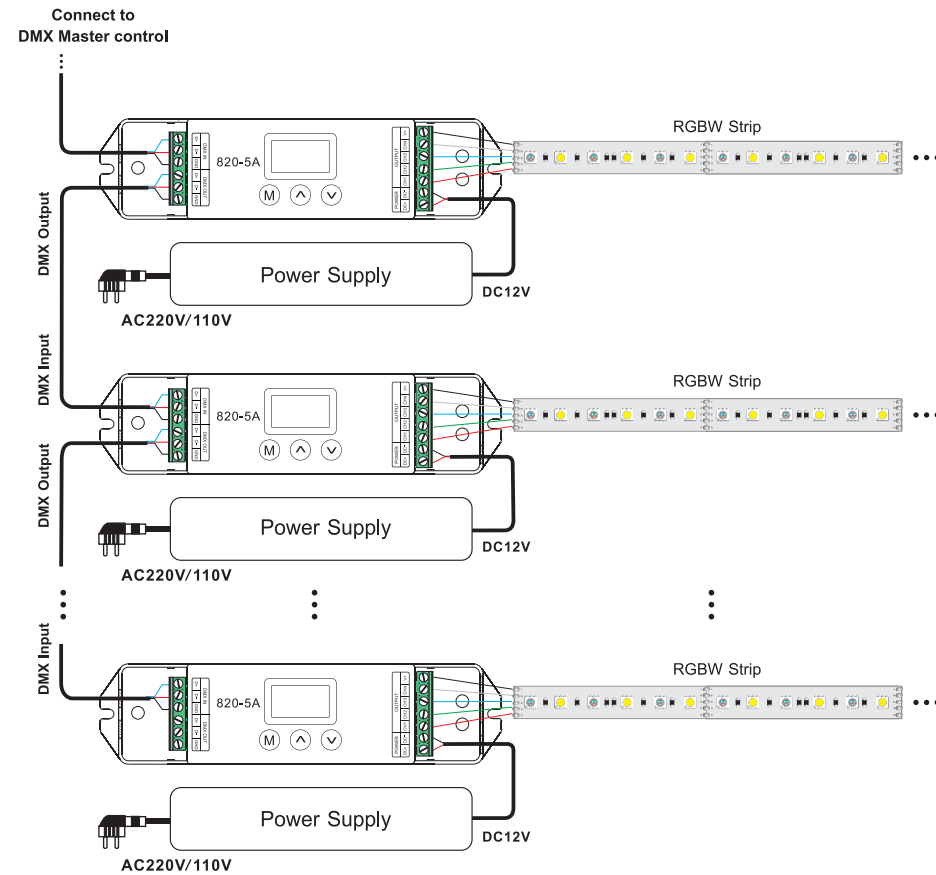

* LED Voltage Chosen:

This controller can wire to the LED lamps with a voltage ranges from DC5-24V if the input voltage equals output voltage, for example:

- the lamp with 5V working voltage, please use 5V power supply,
- the lamp with 12V working voltage, please use 12V power supply,
- the lamp with 24V working voltage, please use 24V power supply.

* LED Power Chosen:

This controller can load a current ranges from 0~20A, a 5V lamp may load a power ranges from 0~100W;
 a 12V lamp may load a power ranges from 0~240W;
 a 24V lamp may load a power ranges from 0~480W.

The power chosen must be 20% higher than the actual load,
 The principle for power chosen: the more the better

2) System Connection Diagram:

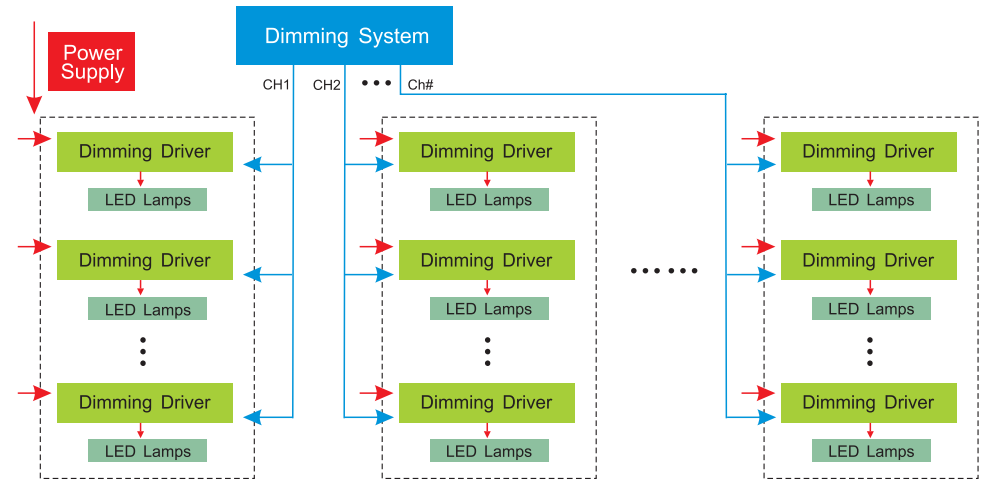

6. Attention:

1. The product shall be installed and serviced by a qualified person.
2. This product is non-waterproof. Please avoid the sun and rain. When installed outdoors please ensure it is mounted in a water proof enclosure.
3. Good heat dissipation will prolong the working life of the controller. Please ensure good ventilation.
4. Please check if the output voltage of any LED power supplies used comply with the working voltage of the product.
5. Please ensure that adequate sized cable is used from the controller to the LED lights to carry the current. Please also ensure that the cable is secured tightly in the connector.
6. Ensure all wire connections and polarities are correct before applying power to avoid any damages to the LED lights.
7. If a fault occurs please return the product to your supplier. Do not attempt to fix this product by yourself.

7. Warranty Agreement:

1. We provide lifelong technical assistance with this product:
 - A 5-year warranty is given from the date of purchase. The warranty is for free repair or replacement and covers manufacturing faults only.
 - For faults beyond the 5-year warranty we reserve the right to charge for time and parts.
2. Warranty exclusions below:
 - Any man-made damages caused from improper operation, or connecting to excess voltage and overloading.
 - The product appears to have excessive physical damage.
 - Damage due to natural disasters and force majeure.
 - Warranty label, fragile label and unique barcode label have been damaged.
 - The product has been replaced by a brand new product.
3. Repair or replacement as provided under this warranty is the exclusive remedy to the customer. LTECH shall not be liable for any incidental or consequential damages for breach of any stipulation in this warranty.
4. Any amendment or adjustment to this warranty must be approved in writing by LTECH only.

★This manual only applies to this model. LTECH reserves the right to make changes without prior notice.