

LT-880 DMX/RDM CV Decoder



LT-880 with the standard RDM remote device management protocol, supports DMX512 signal bi-directional communication, achieves remote management of reading and writing DMX address (DMX master controller must recognize the RDM protocol).

This compact decoder works with DMX512 console. Realize 0-100% brightness and various changing effect. Equipped with DMX standard XLR-3, RJ45 and green terminal interface, easy to operate. And it can control single color, bi-color, RGB LED lights.

1. Product Parameter:

LT-880

- Input Signal: DMX512, RDM
- Input Voltage: 5~24V DC
- Max Current Load: 3A×24CH Max 72A
- Max Output Power: 360W/864W/1728W(5V/12V/24V)
- DMX512 Socket: XLR-3, RJ45, Green Terminal
- Output DMX Channel: 24CH CV PWM
- Working Temperature: -30°C~65°C
- Dimensions: L260×W123×H41mm
- Package Size: L267×W128×H46mm
- Weight(G.W.): 885g

2. Product Size:

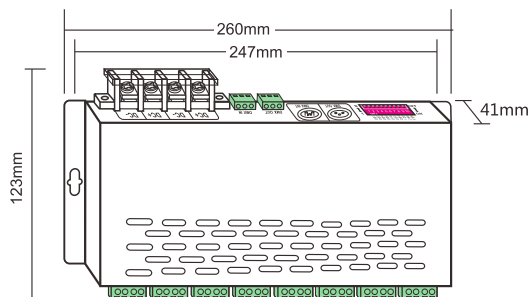

3. Configuration Diagram:

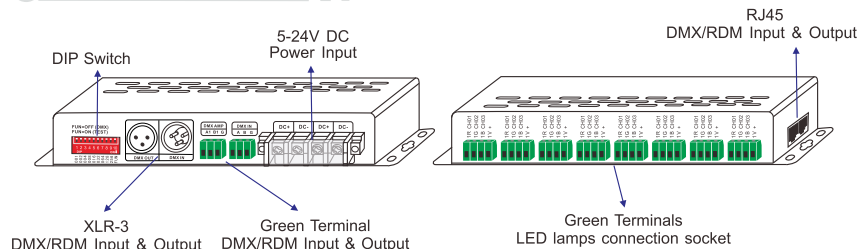

4. Dip Switch Operation:

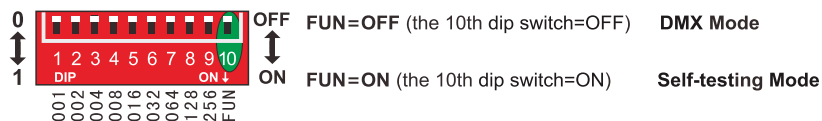

4.1 DMX Mode:

FUN=OFF (the 10th dip switch=OFF) **DMX Mode**

Initial DMX Address Setting:

E.g.1: Set Initial Address To 32. E.g.2: Set Initial Address To 37. E.g.3: Set Initial Address To 178.

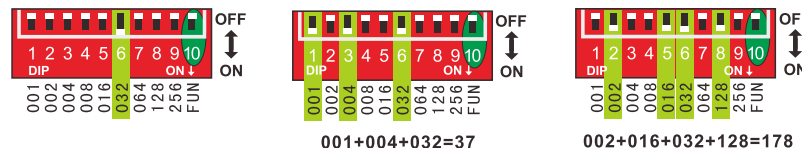

* When Dip switch 1-9 are OFF, the initial DMX address defaults to 1.

4.2 Self-testing Mode:

FUN=ON (the 10th dip switch=ON) **Self-testing Mode**

Dip Switch	1-9=off	1=on	2=on	3=on	4=on	5=on	6=on	7=on	8=on	9=on
Self-test Function	Static Black	Static Red	Static Green	Static Blue	Static Yellow	Static Purple	Static Cyan	White Strobe	7 Colors Jumping	7 Colors Smooth

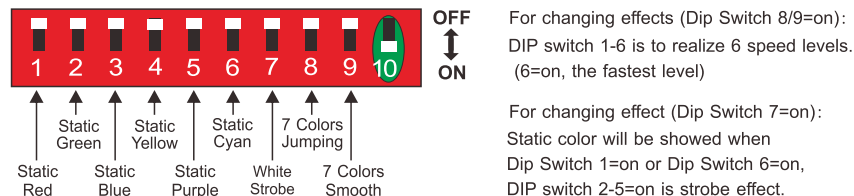

[Attn] When several dip switches are on, subjected to the highest switch value. As the figure above shows, the effect will be 7 colors smooth at 6 speed level.

5. Wiring Diagram:

5.1 Connecting LED lights:

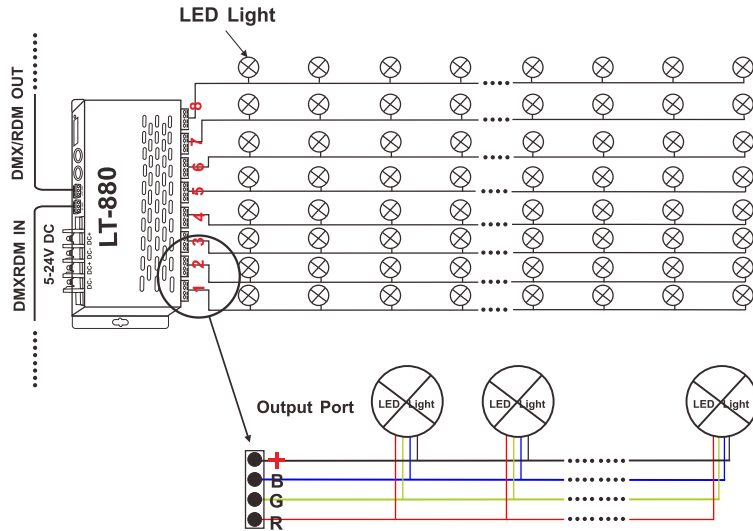

5.2 DMX console connection:

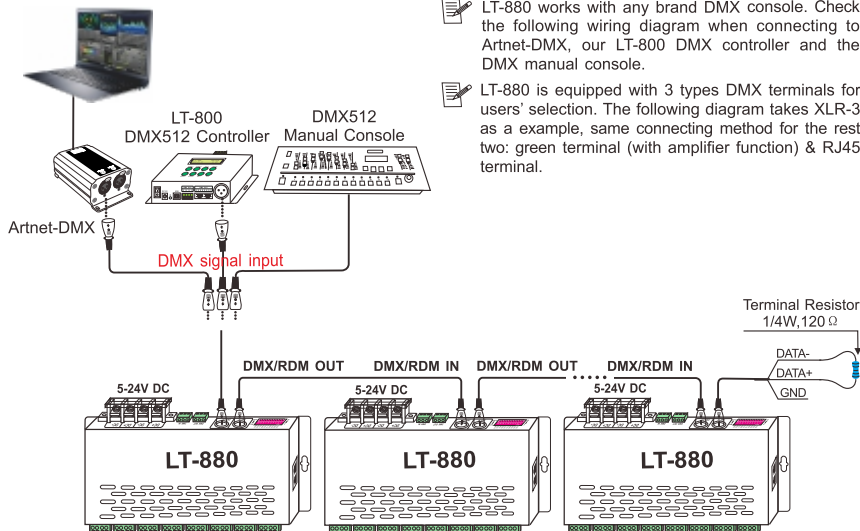

LT-880 works with any brand DMX console. Check the following wiring diagram when connecting to Artnet-DMX, our LT-800 DMX controller and the DMX manual console.

LT-880 is equipped with 3 types DMX terminals for users' selection. The following diagram takes XLR-3 as an example, same connecting method for the rest two: green terminal (with amplifier function) & RJ45 terminal.

6. Attention:

- 6.1 The product shall be installed and serviced by the qualified person.
- 6.2 This product is non-waterproof. Please avoid the sun and rain. When installed outdoors, please ensure it is mounted in a water proof enclosure.
- 6.3 Good heat dissipation will prolong the working life of the controller. Please ensure good ventilation.
- 6.4 Please check if the output voltage of the LED power supply used comply with the working voltage of the product.
- 6.5 Please ensure that adequate sized cable is used from the controller to the LED lights to carry the current. Please also ensure that the cable is secured tightly in the connector.
- 6.6 Ensure all wire connections and polarities are correct before applying power to avoid any damages to the LED lights.
- 6.7 If a fault occurs please return the product to your supplier. Do not attempt to fix this product by yourself.

7. Warranty Agreement:

- 7.1 We provide lifelong technical assistance with this product:
 - A 5-year warranty is given from the date of purchase. The warranty is for free repair or replacement if cover manufacturing faults only.
 - For faults beyond the 5-year warranty, we reserve the right to charge for time and parts.
 - 7.2 Warranty exclusions below:
 - Any man-made damages caused from improper operation, or connecting to excess voltage and overloading.
 - The product appears to have excessive physical damage.
 - Damage due to natural disasters and force majeure.
 - Warranty label, fragile label and unique barcode label have been damaged.
 - The product has been replaced by a brand new product.
 - 7.3 Repair or replacement as provided under this warranty is the exclusive remedy to the customer. We shall not be liable for any incidental or consequential damages for breach of any stipulation in this warranty.
 - 7.4 Any amendment or adjustment to this warranty must be approved in writing by our company only.
- ★This manual only applies to this model. We reserve the right to make changes without prior notice.